

stuart

CH Automatic Flow Switch Pumps

The CH Automatic Flow Switch range of centrifugal multistage pumps offers a simple solution to pressure boosting where a gravity flow of approx. 1 l/min already exists.



Features

- Automatic flow switch activation
- No on-site setting/commissioning
- Built in 'no water' cut out
- No pulsing in operation
- Easy installation
- Reliable
- Quiet operation
- Stainless steel impeller and pump shaft
- Brass and stainless steel pump body
- Continuously rated induction motor

Application

- Ideal for the pressurisation of water to outlets in a positive head application, where an instant boosted supply is required from a simple to install package
- The range is suitable for commercial or domestic use, pumping hot or cold water

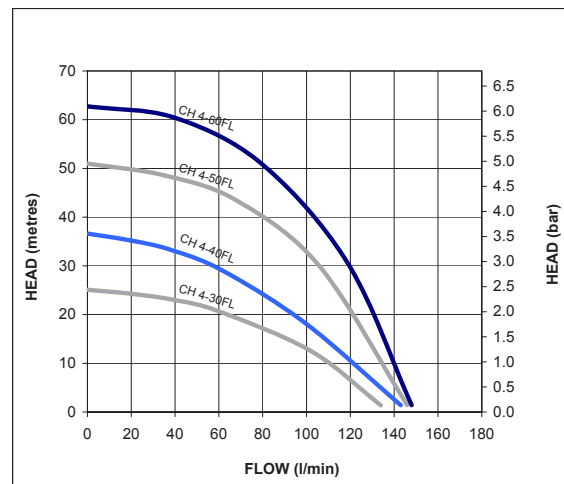

For further advice on selecting the correct pump call
or e-mail info@stpumps.co.uk

pumpassist
HELPLINE +44 (0) 844 98 000 97

Pump Model		CH 4-30 FL 46578	CH 4-40 FL 46596	CH 4-50 FL 46605	CH 4-60 FL 46606
General	Guarantee	1 year			
Features	Pump type	Centrifugal			
	Mechanical seal	EPDM / Carbon / Ceramic			
	Dry run protection	✓	✓	✓	✓
Performance	Maximum head (closed valve)	25 metres	36 metres	50 metres	61 metres
	Performance @ 50 l/min	21 metres	30 metres	45 metres	56 metres
	Performance @ 100 l/min	13 metres	17 metres	31 metres	41 metres
	Maximum flow	130 l/min	140 l/min		
	Minimum static inlet pressure	0.05 bar (0.5 metres)			
	Maximum static inlet pressure	1.0 bar (10 metres)			
	Maximum static outlet pressure	1.2 bar (12 metres)			
	Maximum working pressure*	600 kPa (6 bar)	900 kPa (9 bar)		
	Maximum ambient air temperature	50 °C			
	Min / Max water temperature**	Min 4 °C / Max 65 °C			
Flow switch sensitivity (approx)	1 l/min				
Connections	Pump connections	G 1¼ female (inlet), G 1 female (outlet)			
Motor	Type	Induction, auto-reset thermal trip			
	Duty rating	Continuous (S1) @ 2.5 l/min and above			
Electrical	Power supply / phase / frequency	230 V a.c. / 1 / 50 Hz			
	Current (full load)	3.6 Amps	5.4 Amps	7.3 Amps	8.8 Amps
	Power consumption	805 Watts	1210 Watts	1640 Watts	1980 Watts
	Fuse rating	13 Amps			
	Power cable (pre-wired)	0.75 metres			
Physical	Enclosure protection	IPX5			
	Length	360 mm	384 mm	431 mm	456 mm
	Width	155 mm		187 mm	
	Height (excluding hoses)	228 mm		247 mm	
	Weight (including fittings)	10.2 Kg	12.0 Kg	15.5 Kg	18.0 Kg

* The maximum pressure that can be applied to the pump under any installation conditions.

** A stored water temperature of 60 °C is considered sufficient to meet all normal requirements and will minimise deposition of scale in hard water areas.

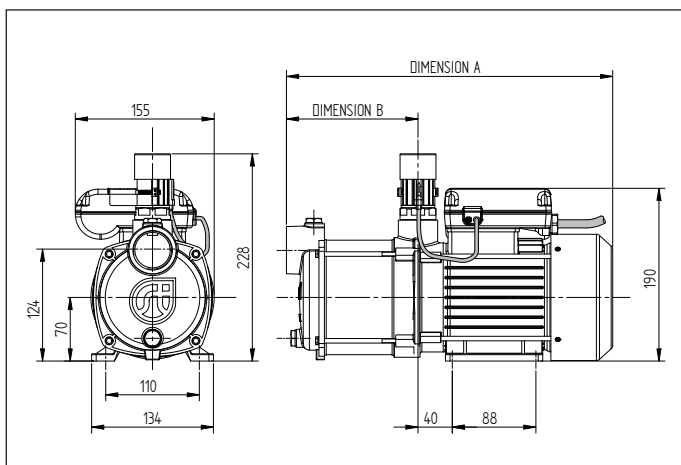

Pump Description	Dim. 'A'	Dim. 'B'
CH 4-30 FL	360 mm	146 mm
CH 4-40 FL	384 mm	170 mm

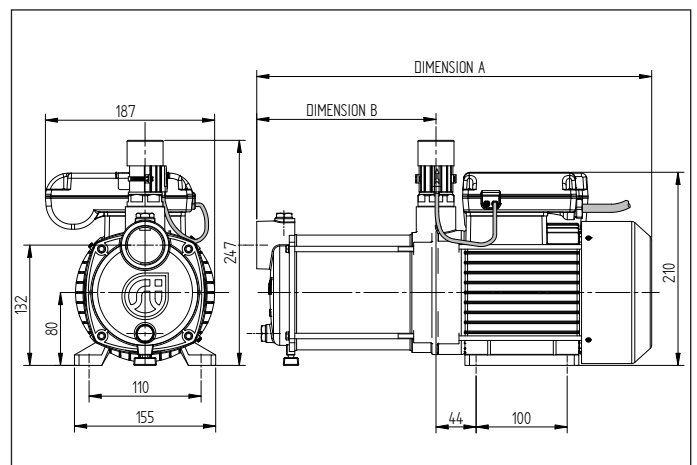

Pump Description	Dim. 'A'	Dim. 'B'
CH 4-50 FL	431 mm	198 mm
CH 4-60 FL	456 mm	222 mm

Stuart Turner Limited reserves the right to amend specifications without notice.